

SUBJECT: ALL PC-12 SERIES AIRCRAFT - VENDOR MODIFICATIONS FOR CREW SEATS

To all Customers, Operators and Service Centers:

Date: Oct 15/10

This Service Letter is issued to draw attention to the following information:

Effective from MSN 1275, the Ipeco Crew Seats are being introduced with a softer seat pan cushion.

The Crew Seat vendor has therefore issued two Service Bulletins which modify the crew seats:

1. For MSN 545, 684 thru 888 and 1001 thru 1274:
 - Ipeco Service Bulletin 318-25-04 allows the installation of a softer cushion on seat part numbers 959.30.01.143 thru 146. The new cushion is softer, wider and longer than the existing cushion.
2. For MSN 1275 and up:
 - Ipeco Service Bulletin 318-25-05 allows for reverting to the harder cushion on seat part numbers 959.30.01.163 thru 166.

For price and availability, please contact Ipeco directly by following the instructions given on page 4 of the attached Service Bulletins.

Operators requiring any additional information on this subject, please contact one of the addresses given below:

PILATUS AIRCRAFT LTD.,
CUSTOMER SUPPORT MANAGER,
CH-6371 STANS,
SWITZERLAND.

General Aviation
Tel : + 41 41 619 3333
Fax: + 41 41 619 7311
eMail: SupportPC12@pilatus-aircraft.com

PILATUS BUSINESS AIRCRAFT LTD.,
PRODUCT SUPPORT DEPARTMENT,
11755 AIRPORT WAY,
BROOMFIELD, CO 80021.
USA

Tel : 303 465 9099
Fax: 303 465 6040
eMail: Productsupport@PilBal.com

PILATUS AUSTRALIA (Pty.) LTD.,
17 James Schofield Drive,
Adelaide Airport SA 5950,
AUSTRALIA

Tel : +61 (08) 8234 4433
Fax: +61 (08) 8234 4499
Free Call: 1800 445 007
eMail: SupportPC12@pilatus.com.au

Attachments: Ipeco Service Bulletins 318-25-04 and 318-25-05

INTENTIONALLY BLANK



SERVICE BULLETIN EQUIPMENT / FURNISHINGS

FLIGHT COMPARTMENT

**REPLACEMENT OF SEAT
PAN CUSHION AND COVER**

PILATUS PC-12

SERVICE BULLETIN NUMBER

318-25-04

ISSUE 1

**ISSUED BY:
IPECO
AVIATION WAY
SOUTHEND ON SEA
ESSEX SS2 6UN
ENGLAND**

TELEPHONE: 01702 549371 FAX 01702 540782

A DIVISION OF IPECO HOLDINGS LTD. REGISTERED IN ENGLAND NO. 672443



SERVICE BULLETIN

SERVICE BULLETIN No.
318-25-04

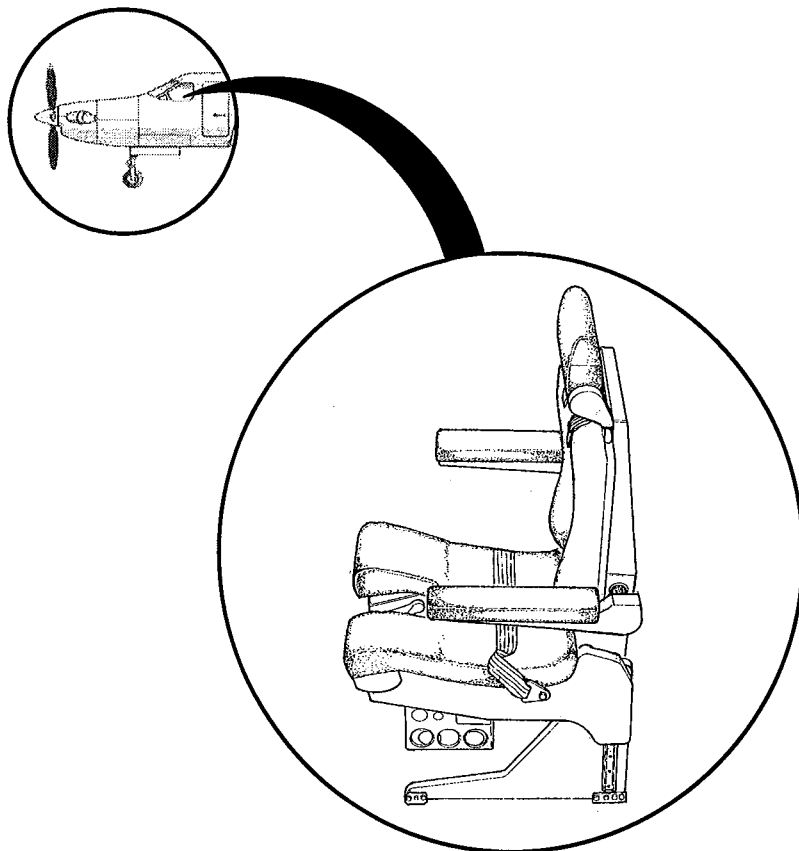

LOCATION OF SERVICE BULLETIN CONTENT

COMPILED BY: W. Barnes
W. BARNES
PRODUCT SUPPORT
MANAGER

APPROVED BY: S. Herson
S. HERSON
SECTION MANAGER
CREW SEAT PROGRAMS

318-25-04



SERVICE BULLETIN

PLANNING INFORMATION

Effectivity

Pilatus PC-12 aircraft fitted with Ipeco pilot and co-pilot seats of the following part numbers:-

	Ipeco Part No.	Pilatus Part No.
Pilot Seat:	3A318-0007-00-2	959.30.01.143
	3A318-0007-01-2	959.30.01.143
	3A318-0007-03-2	959.30.01.145
Co-pilot Seat	3A318-0008-00-2	959.30.01.144
	3A318-0008-01-2	959.30.01.144
	3A318-0008-03-2	959.30.01.146

Classification

Operators discretion

Reason

Request from customer for softer (lower density foam) seat pan cushion.

318-25-04



SERVICE BULLETIN

Description

Removal of existing seat pan cushion and cover and fitting with new parts.

Approval

The modification information contained in this Service Bulletin revises the approved configuration of the seat, however it does not affect the seats certification.

Refer to Ipeco Post Test Modification Report 318-03, for detail

Warranty

The actions listed in this Service Bulletin are not covered by Ipeco Warranty.

Manpower

The incorporation of this Service Bulletin is estimated to require ¼ man-hour per seat.

318-25-04



SERVICE BULLETIN

Material Cost and Availability

For seat part numbers 3A318-0007-00-2, 3A318-0007-03-2, 3A318-0008-00-2 and 3A318-0008-03-2, Mod Kit – 318 Seat Pan Cushion - 3M800-0679.

For seat part numbers 3A318-0007-01-2 and 3A318-0008-01-2, Mod Kit – 318 Seat Pan Cushion – 3M800-0680.

Instructions for ordering:-

Purchase Order to be issued to:-

Ipeco
Sales Department
Aviation Way
Southend-on-Sea
Essex SS2 6UN
England

Telephone: 01702 549371

containing the following information:-

- Title and part number
- Quantity required
- Name of Airline/Operator
- Part number of seat

Parts will be shipped within 6–10 weeks of receipt of Purchase Order.

Operators in the North American market should order from:-

Ipeco Inc
2275 Jefferson St.
Torrance
California 90501
USA

Telephone: 310 783 4700

318-25-04



SERVICE BULLETIN

Weight

Not affected

Tooling

None

Software Accomplishment Summary

Not applicable

References

Component Maintenance Manual SM681 (25-11-66)
Post Test Modification Report 318-03

318-25-04



SERVICE BULLETIN

Accomplishment Instructions

Note 1: Item numbers shown thus:- (*-**) refer to items from the Illustrated Parts List (part of CMM), i.e. (1-30) refers to Figure 1, Item 30.

Note 2: Item numbers shown thus:- (*) refer to items from the mod kit, see table 1.

1. The following instructions can be carried out with the seat fitted on the aircraft. If the seat is removed from the aircraft refer to the aircraft maintenance manual for details.
2. Remove pan cushion (174) and cover (1-168) (1-168A). Refer to seat CMM.
3. Fit replacement cover (2) to new pan cushion (1) and locate onto seat making sure that the cushion is centrally positioned on the seat pan. Refer to seat CMM.
4. After modification, operator should mark by vibro-etch or similar method, the Service Bulletin number (318-25-04) and issue onto the seat identification label (nameplate) which is located on base structure back panel.

318-25-04



SERVICE BULLETIN

MATERIAL INFORMATION

The materials listed in Table 1 are the full contents of 1 Mod Kit for seat part numbers 3A318-0007-00-2, 3A318-0007-03-2, 3A318-0008-00-2 and 3A318-0008-03-2, (1 Mod Kit required per seat).

TABLE 1

ITEM No.	NEW PART NUMBER	KEYWORD	OLD PART NUMBER	QTY
1	0A318-0569	CUSHION ASSY PAN	0A318-0521	1
2	0A318-0571CR	COVER ASSY PAN CUSHION	0A318-0525CR	1

The materials listed in Table 2 are the full contents of 1 Mod Kit for seat part numbers 3A318-0007-01-2 and 3A318-0008-01-2, (1 Mod Kit required per seat).

TABLE 1

ITEM No.	NEW PART NUMBER	KEYWORD	OLD PART NUMBER	QTY
1	0A318-0569	CUSHION ASSY PAN	0A318-0521	1
2	0A318-0571EG	COVER ASSY PAN CUSHION	0A318-0525EG	2

Unless otherwise instructed in the Accomplishment Instructions section of this Service Bulletin, all old parts removed from the seat are to be discarded.

318-25-04



SERVICE BULLETIN EQUIPMENT / FURNISHINGS

FLIGHT COMPARTMENT

**REPLACEMENT OF SEAT
PAN CUSHION AND COVER**

PILATUS PC-12

SERVICE BULLETIN NUMBER

318-25-05

ISSUE 1

**ISSUED BY:
IPECO
AVIATION WAY
SOUTHEND ON SEA
ESSEX SS2 6UN
ENGLAND**

TELEPHONE: 01702 549371 FAX 01702 540782

A DIVISION OF IPECO HOLDINGS LTD. REGISTERED IN ENGLAND NO. 672443



SERVICE BULLETIN

**SERVICE BULLETIN No.
318-25-05**

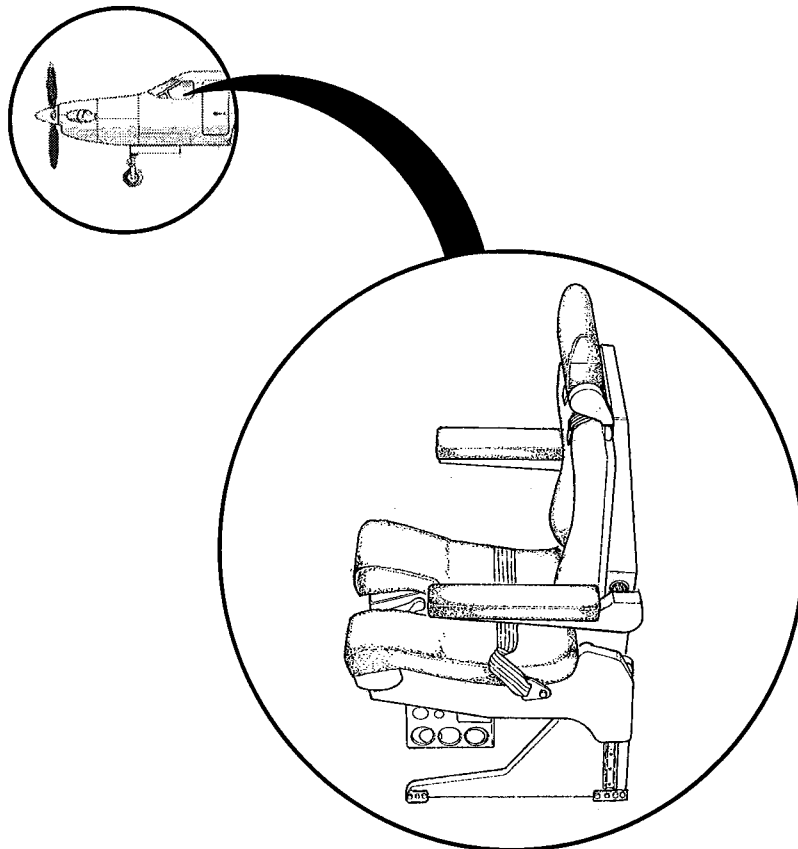

LOCATION OF SERVICE BULLETIN CONTENT

COMPILED BY: 
W. BARNES
PRODUCT SUPPORT
MANAGER

APPROVED BY: 
S. HERSON
SECTION MANAGER
CREW SEAT PROGRAMS

318-25-05



SERVICE BULLETIN

PLANNING INFORMATION

Effectivity

Pilatus PC-12 aircraft fitted with Ipeco pilot and co-pilot seats of the following part numbers:-

	Ipeco Part No.	Pilatus Part No.
Pilot Seat:	3A318-0007-00-3	959.30.01.163
	3A318-0007-01-3	959.30.01.163
	3A318-0007-03-3	959.30.01.165
Co-pilot Seat	3A318-0008-00-3	959.30.01.164
	3A318-0008-01-3	959.30.01.164
	3A318-0008-03-3	959.30.01.166

Classification

Operators discretion

Reason

To allow the use of original pan cushion and cover on latest configuration seats.

318-25-05



SERVICE BULLETIN

Description

Removal of existing pan cushion and cover and fitting with new parts.

Approval

The modification information contained in this Service Bulletin reverts the seat configuration to that of the originally certified seat as such this Bulletin does not require EASA or other regulatory agency approval.

Warranty

The actions listed in this Service Bulletin are not covered by Ipeco Warranty.

Manpower

The incorporation of this Service Bulletin is estimated to require $\frac{1}{4}$ man-hour per seat.

318-25-05



SERVICE BULLETIN

Material Cost and Availability

For seat part numbers 3A318-0007-00-3, 3A318-0007-03-3, 3A318-0008-00-3 and 3A318-0008-03-3, Mod Kit – Seat Pan Cushion - 3M800-0681.

For seat part numbers 3A318-0007-01-3 and 3A318-0008-01-3, Mod Kit – Seat Pan Cushion – 3M800-0682.

Instructions for ordering:-

Purchase Order to be issued to:-

Ipeco
Sales Department
Aviation Way
Southend-on-Sea
Essex SS2 6UN
England

Telephone: 01702 549371

containing the following information:-

- Title and part number
- Quantity required
- Name of Airline/Operator
- Part number of seat

Parts will be shipped within 6–10 weeks of receipt of Purchase Order.

Operators in the North American market should order from:-

Ipeco Inc
2275 Jefferson St.
Torrance
California 90501
USA

Telephone: 310 783 4700

318-25-05



SERVICE BULLETIN

Weight

Not affected

Tooling

None

Software Accomplishment Summary

Not applicable

References

Component Maintenance Manual SM681 (25-11-66)

318-25-05



SERVICE BULLETIN

Accomplishment Instructions

Note 1: Item numbers shown thus:- (*-**) refer to items from the Illustrated Parts List (part of CMM), i.e. (1-30) refers to Figure 1, Item 30.

Note 2: Item numbers shown thus:- (*) refer to items from the mod kit, see table 1.

1. The following instructions can be carried out with the seat fitted on the aircraft. If the seat is removed from the aircraft refer to the aircraft maintenance manual for details.
2. Remove pan cushion (175) and cover (1-169) (1-169A). Refer to seat CMM.
3. Fit replacement cover (2) to new pan cushion (1) and locate onto seat making sure that the cushion is centrally positioned on the seat pan. Refer to seat CMM.
4. After modification, operator should mark by vibro-etch or similar method, the Service Bulletin number (318-25-05) and issue onto the seat identification label (nameplate) which is located on base structure back panel.

318-25-05



SERVICE BULLETIN

MATERIAL INFORMATION

The materials listed in Table 1 are the full contents of 1 Mod Kit for seat part numbers 3A318-0007-00-3, 3A318-0007-03-3, 3A318-0008-00-3 and 3A318-0008-03-3, (1 Mod Kit required per seat).

TABLE 1

ITEM No.	NEW PART NUMBER	KEYWORD	OLD PART NUMBER	QTY
1	0A318-0521	CUSHION ASSY PAN	0A318-0569	1
2	0A318-0525CR	COVER ASSY PAN CUSHION	0A318-0571CR	1

The materials listed in Table 2 are the full contents of 1 Mod Kit for seat part numbers 3A318-0007-01-3 and 3A318-0008-01-3, (1 Mod Kit required per seat).

TABLE 1

ITEM No.	NEW PART NUMBER	KEYWORD	OLD PART NUMBER	QTY
1	0A318-0521	CUSHION ASSY PAN	0A318-0569	1
2	0A318-0525CR	COVER ASSY PAN CUSHION	0A318-0571EG	1

Unless otherwise instructed in the Accomplishment Instructions section of this Service Bulletin, all old parts removed from the seat are to be discarded.

318-25-05